



FTC-P-18-5 & FTC-P-24-8

**High-Pressure
Self-Contained
Misting System
User Manual**



CAUTION

- Carefully read and understand the entire user manual before attempting to install, operate, or perform maintenance on this equipment.
- Contact your supplier if you do not understand these instructions.
- Failure to follow these instructions may lead to serious injury or death.
- Retain these instructions for future reference.

All operators must read and understand this manual.

Table of Contents

Overview of High-Pressure Misting System.....3

Start-up and Operation Procedures.....3

Maintenance5

Oil Change Instructions 6

Troubleshooting8

Replacement Parts10

Consumable/Common Parts.....10

Warranty 11

Appendix 12

Overview of High-Pressure Misting System

Thank you for choosing Advanced Misting Systems as your provider for high-pressure misting systems. Advanced Misting Systems is committed to providing its customers with reliable high-pressure cooling systems engineered with quality components to meet their cooling needs.

Advanced Misting System's high-pressure misting system provides superior cooling by combining small orifice misting nozzles with a high-pressure pump to create a very fine mist or fog. This fine mist will quickly evaporate through a process called flash evaporation reducing the temperature of the ambient air.

Advanced Misting Systems pairs the misting system with durable fans to reduce the temperature in the desired location.

Start-up and Operation Procedures

High-pressure misting systems require electricity and water to function properly. Electrical connections are needed to provide power to the pump motor and the fan motor. Use the proper electrical source to ensure the system will operate correctly. The water should be supplied to the tank through the garden hose connection on the back of the unit.

1. Connect the water supply to the 3/4" female garden hose adapter on the back of the unit.

Purge your hose or water line of debris before attaching it to the unit. The ideal water supply should meet the following conditions:

- Flow rate of 1 GPM or more
- Water less than 7.5 pH
- Pressure between 15-75 PSI
- Dissolved solid content less than 500 PPM

2. Connect the unit to a power supply.

This system is equipped with a NEMA 5-15 plug for 110 volt electrical connections. The amperage requirements are located on the motor plates of both the pump motor and fan motor. Do not use extension cords or other adapters for electrical connections unless the components are rated for heavy duty outdoor use with at least 15A rating at 125V. Common household electrical systems have plugs rated to 15 amps. Common household circuit breakers are overloaded at 20 amps. Consult a certified electrician if you are unsure about your power supply.



WARNING

**ELECTRICAL SHOCK HAZARD: Serious injury or death is possible.
Only connect the power supply plug to a properly grounded receptacle.**

3. Connect to water supply or fill water tank.

Once the hose is connected to the inlet at the back of the tank, turn on the water supply and allow the tank to begin filling. The unit may be operated with the water supply connected or disconnected. The approximate run time is 3 – 4 hours, depending on the on/off cycle settings used.

If operating with the water supply disconnected, wait for the tank to fill up and then turn off the water supply and disconnect the garden hose. When the tank is full a float valve will automatically shut off the water supply inlet, stopping the tank from being over filled. The inlet valve will open when the tank water level drops below full, and if there is a water supply connected, the tank will continue to fill until water level rises and the float valve shuts off the inlet again.

The water tank has an auxiliary fill cap on the top of the tank. This cap can be removed to fill the water tank with the exception that any water added to the tank this way will not be filtered by the built-in water filter. It is strongly recommended that the garden hose inlet at the back of the unit always be used to fill the water tank. Impurities in municipal water supplies may not be visible, and over time can cause premature clogging of nozzles.

4. Purge air from the system.

During this process, a steady stream of water will exit from the misting ring, so be sure to perform this step in an area where water will not damage any property or goods.

Remove one misting nozzle from the top side of the misting ring. This will allow any air in the system to be forced out and the system will fill with water. With the misting nozzle removed (and water in the tank) activate the pump by pressing the “ON” button on the control panel. If the “Warning” light is on you may need to reset the low water level indicator by pressing the “OFF” button. The red warning light should go off and you can now activate the pump. It will take approximately 30 seconds to purge the air from the entire system. Once a steady stream of water is flowing from the misting ring, turn off the pump and install the misting nozzle back onto the misting ring. The misting system should now be ready to operate. Test the system by turning on the pump and waiting a few seconds while pressure builds up in the system. You will see the mist coming from the misting nozzles once the system is fully pressurized. The mist should form a uniform cone shape when exiting the nozzle. If the cone is not even, or if the nozzle appears to be leaking, see the troubleshooting section. Purging is typically only needed during initial setup, and/or after extended periods of non-use.

5. Turning on the Fan. Cool Caddie units have an integrated power cord to supply power to the fan. The male and female ends of the plug must be connected for the fan to operate.



Figure 1 - The Fan plugs into the power cord attached at the base of the unit.

To begin operation of the fan, turn speed selection knob on the fan to your desired speed. Fans have three different speeds and an oscillator that may be switched ON or OFF. Fan speed may also be controlled by the control panel knob on the back of the tank. Place the misting system in the desired location and lock the wheel in place to prevent the unit from moving during operation.

6. Turning off the system. Turn the fan speed control knob to the “OFF” position. Turn off the pump by pressing the “OFF” button on the back of the unit.

Maintenance

1. Nozzles. Always turn off the pump before removing the misting nozzles. Nozzles should be checked regularly to ensure good misting performance. The mist should emit from the nozzle in an even cone shape. If the mist is not an even cone shape the nozzle needs to be cleaned or replaced. To clean a nozzle, first remove it from the misting ring. Disassemble the nozzle and soak the nozzle tip and impeller in vinegar or a household cleaning product used for dissolving calcium, lime, and iron oxide deposits (commonly known as CLR®). Do not soak the spring or the body of the nozzle. After soaking, rinse with water and reattach to the misting ring, do not use tools. The nozzles should function properly when screwed in by hand.

2. Pump. The pressure in the misting system comes from a water pump that is directly driven by an electric motor. The pump comes pre-filled with oil for immediate operation. The oil requires an initial change after 50 hours of service, and additional oil changes every year or 500 hours. Use an ISO 68 gear oil (or equivalent). When changing the oil disconnect the electricity to the system. **Do not run the pump without oil in the crankcase.** Check oil seasonally to make sure the pump is adequately filled.



Figure 2 - Exploded view of misting nozzle. Note the anti-drip stopper must not be lost during disassembly.

Oil change instructions:

Do not attempt to change the oil while the unit is plugged in and always allow the pump and motor to cool before performing the oil change.

A) Remove the four screws holding on the back cover plate (See figure 3).

B) Unscrew the plastic fill plug from the top of pump housing (See figure 4). It is located on the top forward area of the pump housing when viewed from the back of the unit.

C) Place a catch pan, bottle, or other container suitable for collecting used oil on the ground below the oil drain valve (See figure 4).



Figure 3 - Back view of the Cool Caddie. The four arrows point to the screws holding the back cover plate onto the unit.



Figure 4 – Oil fill plug and drain valve location.



Figure 5 - Oil drain valve with end cap removed.

D) Open oil drain valve. Turn the end of the oil drain valve counter-clockwise and oil will begin to flow out of the drain valve. Remove the drain valve end cap completely if the oil does not flow or flows slowly. Allow the oil to flow until no more oil is able to drain from the pump housing.

E) Close the oil drain valve. Make sure it is tightened completely. You will know that the valve is not closed if oil begins to leak when refilling the pump with new oil. Leave your catch pan in place in case of an accidental spill or leak.

F) Fill the included squeeze bottle with ISO 68 gear oil or equivalent. See the oil capacity below. (A higher or lower viscosity gear oil may be used depending on the operating environment in your region.)



Figure 6 - Oil bottle.

Oil Capacity	
Minimum	5 Oz. (Or 150 mL)
Maximum	6 Oz. (Or 175 mL)

G) There are different ways to fill the pump with oil using the squeeze bottle. The two suggested options are horizontal and vertical bottle orientation. The horizontal method requires you to place the spout of the squeeze bottle directly over the top of the oil fill hole and *GENTLY* squeeze the bottle, allowing a stream of oil to drop down into the hole (See figure 7).



Figure 7 - Horizontal bottle spout filling the pump with oil.

For vertical method, turn the bottle upside down and insert the spout into the fill hole (See figure 8). With the spout in the hole, firmly squeeze the bottle to force oil into the pump housing. The vertical method is much quicker, but can be difficult for individuals with larger hands and can cause some oil to be lost when turning the bottle upside down. Clean up any spills after the fill process so that you will be able to detect any new oil leakage.



Figure 8 – Vertical bottle orientation.

3. Filters. The water filter should be checked frequently and replaced if needed. The filter life depends on the water source and quality of incoming water. If the filter is discolored, dirty, covered in debris, or damaged replace the filter immediately. To check the filter, remove the back cover screws (See figure 3) and unscrew the blue filter housing from the bracket in the rear of the unit. When replacing the filter, it is also good practice to clean the housing with a very dilute bleach solution. Use one cup of bleach mixed with one gallon of water and scrub the inside of the housing using a stiff brush, sponge, or rag. Make sure the sealing O-ring is in place when reattaching the filter housing, then firmly hand tighten and check for leaks.

4. Storage. When storing the system for more than a few days it is important to drain the water. Draining the water prevents formation of algae. Drain the tank completely by unscrewing the cap underneath the tank. It may be necessary to tilt the system to drain all the water. Take caution when tilting the unit because the weight of the fan can cause an unsafe situation if tipped over. Also drain the filter housing to preserve the filter. Store the unit in a dry location away from areas that are subject to excessive heat, dust, humidity, freezing, or damage from nearby equipment. If freezing conditions are likely, you can flush your pump with a 50/50 solution of anti-freeze/water to prevent severe damage. Also drain any supply hoses.

For initial operation after a long duration of non-use it is necessary to flush the system of particles. Remove the nozzles from the nozzle rings and place the system in a water safe environment. Power up the system and allow water to flow through the nozzle openings for a few seconds. After flushing the system, reattach the nozzles and tightening by hand.

Troubleshooting

Problem	Potential Cause	Corrective Action
Fan will not turn on.	Power supply connections	Confirm the control knobs are in the ON position. Confirm the power cords are connected. Confirm that the power supply is on. Confirm that power is present at the electrical outlet.
Nozzles will not mist.	Supply line connection	Confirm the fan water line is connected to the water supply line coming from the base of the unit. Confirm the tank has water.
	Pump not operational.	Confirm the warning light is off and the tank has water in it. Review pump troubleshooting.
	System air lock.	Review air purge procedure (page 4).
Surfaces get wet.	Unit too close.	Optimum evaporation occurs at least 10 ft. from the fan. Relocate the fan.
	Too much mist being produced for the environment.	Use the low speed setting on the fan, turn on oscillation, or relocate fan. Install nozzle plugs to reduce the amount of mist. The misting fan must have at least four nozzles to be operational. Visit www.advancedmistingystems.com for parts.
Nozzle leaks during operation.	Nozzles are clogged.	Remove debris from nozzle tip by cleaning.
	Nozzles are loose.	Turn off the system and relieve pressure to the mist rings, loosen and then hand-tighten nozzles.
	Nozzle O-ring is worn.	Replace nozzle.
	Ant-drip parts may be worn.	Clean or replace nozzle.
Pump will not run.	Power cord is unplugged. Power supply is OFF. Water supply is Empty or OFF.	Plug in power supply to pump. Turn ON supply power to pump. Turn ON supply water to pump or fill the tank.

	Supply circuit breaker OFF.	Confirm correct voltage and amperage is being supplied.
	No water supplied.	Confirm the supply water is flowing to the tank. Inspect filter. Replace dirty filter which can restrict flow.
Circuit interrupter is tripped.		Press the reset button on the pump motor.
	Pump motor may be damaged.	Motor bearing may have caused pump to seize. Have service shop inspect and replace if necessary.
	Pump head may be damaged.	Motor may have shorted or been overloaded. Have a service shop inspect. Crank bearing/connecting rods may be damaged. Have a service shop inspect.
Pump chatters.	Pump is being starved of water.	Ensure that clean water is being supplied, especially at system start-up. Check for clogged pipes or tubes.
	Broken or worn bearing.	Have service shop inspect and replace if necessary.
	Stuck inlet/discharge valves.	Have service shop inspect valves and replace if necessary.
Pump leaks.	Water is leaking.	Have service shop inspect seals and replace if necessary.
	Oil is leaking.	Tighten filler cap and drain plug. Fill crankcase to specified capacity. Have service shop inspect seals and replace if necessary.
Pump is on but no mist is produced.	There may be a leak in the system.	Confirm that nozzles are intact and create a good seal with the misting ring.
		Check for loose hose fitting in manifold line.
	There may be an air-lock	See air purge instructions.
	The pump's pressurization components may be damaged.	This is true if the pump makes a clicking sound. The pump head can be replaced, have a service shop inspect.
	Pump strainer clogged.	The pump has a strainer on the pump inlet that protects the pump from debris. This can become clogged and prevent water supply to the pump. Clean out and reinstall. (See figure 10).

Water sprays from nozzles after system is shut down. Anti-drip not functioning. Check integrity of anti-drip stopper and spring. Replace nozzles if necessary.

Filter housing leaks. O-Ring failure. Inspect placement and integrity of O-ring. Replace if necessary.

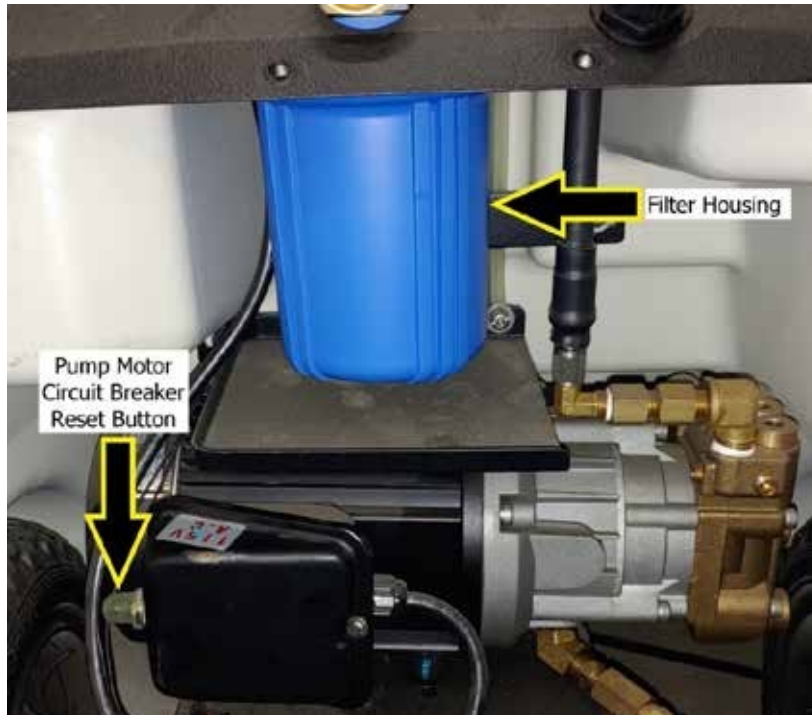

Figure 9 – Location of filter housing and circuit breaker reset button.

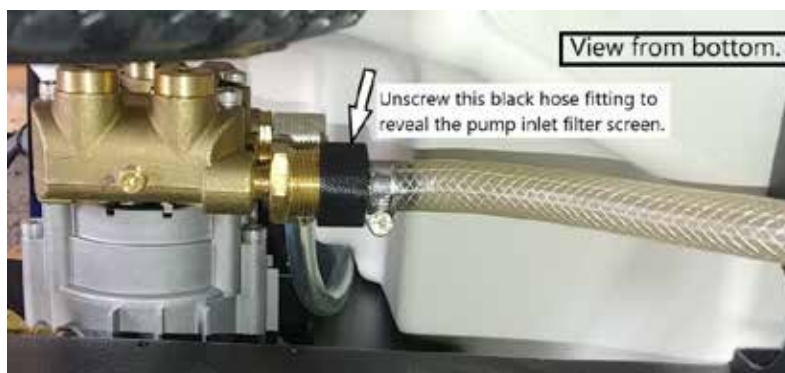
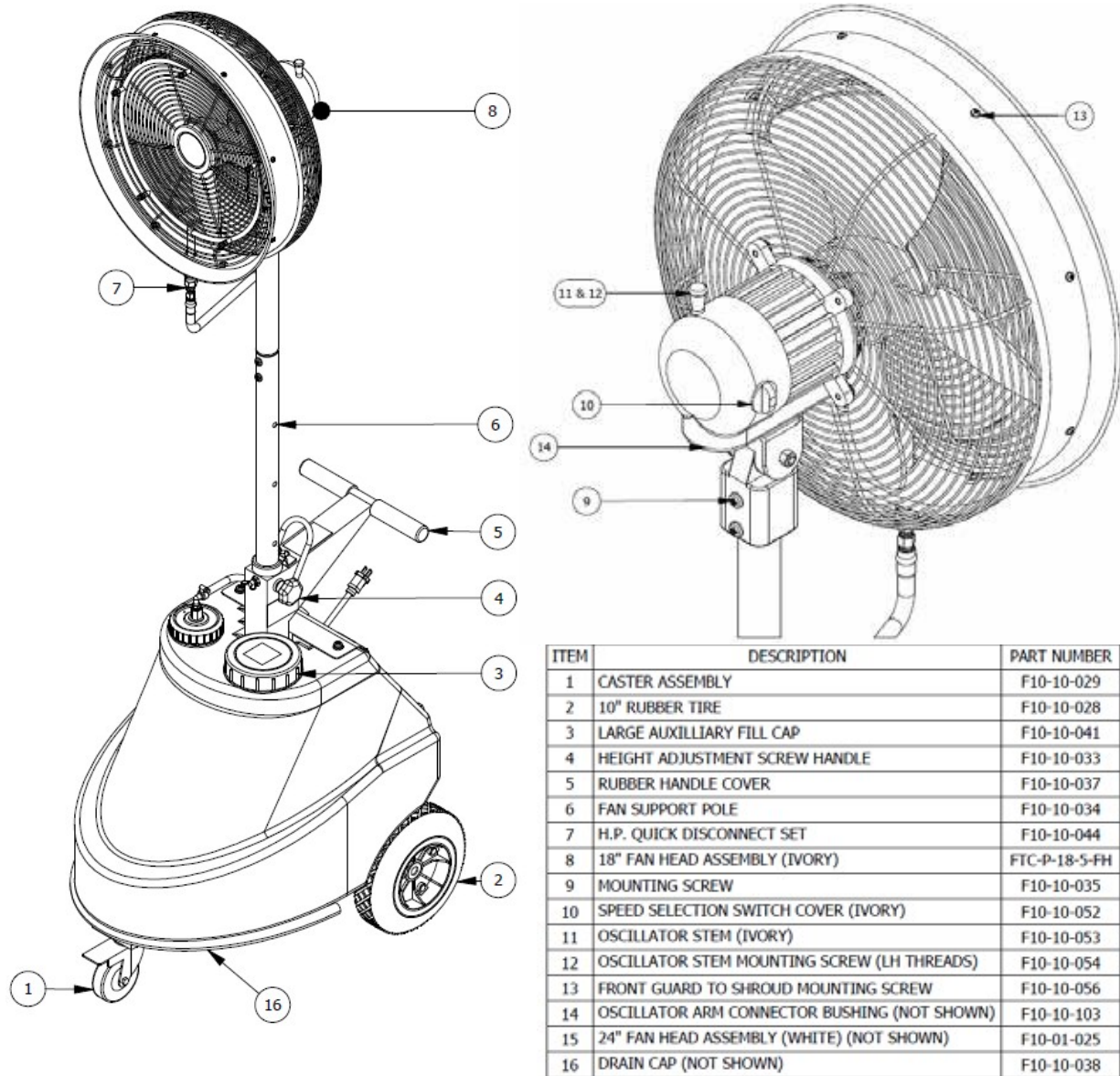

Figure 10 – Location of pump filter screen.

Replacement Parts



Please contact Advanced Misting Systems for a complete repair parts drawing.

Consumable/Common Parts

Misting Nozzle	F10-08-001
Water Filter	F10-10-001
Gear Oil	F02-06-001
Nozzle Plug	F10-08-002 (Recommended for environments with humidity greater than 80%)

Advanced Misting Systems ONE (1) YEAR LIMITED WARRANTY

All Advanced Misting Systems products are warranted for a period of one (1) year for defects in workmanship and materials under normal use and service. This warranty is extended solely to the original purchaser. In order to initiate this warranty, the Product

Registration Form must be completed and sent to Advanced Misting Systems, along with a copy of the purchase invoice, within 30 days of purchase.

In General: If a Advanced Misting Systems product fails because of defect in material or workmanship under normal use and maintenance within one year from date of purchase, we will, at our option and after inspection, repair or replace the defective product.

About your Warranty: **Advanced Misting Systems** products, like all mechanical devices, need periodic parts and service to perform well. Normal use and service means not to operate in excess of recommended maximum speeds, pressures, temperatures or using fluids not recommended or compatible with component materials.

This warranty does not apply to any component which has been repaired or altered to affect the performance or reliability of the product. Similarly, the warranty is void if the manufacture date or the serial number has been removed or if the equipment has been altered or modified.

Advanced Misting Systems does not warranty components due to normal wear including nozzles, pumps, motors, and seals. Advanced Misting Systems does not warranty components due to misuse, abuse, neglect or improper maintenance, shipping, handling, warehousing or improper installation. This warranty excludes wear items such as water filters, spray nozzles, or pumps that have been run without water supplied or oil filled to specified capacities; damage or malfunctions

resulting from accidents, abuse, modifications, alterations, or improper servicing or freezing or chemical deteriorations. This warranty excludes failures due to acts of God and other force majeure events beyond The manufacturer's control.

This warranty does not cover normal maintenance such as oil changes, water filters, adjustments, or cleaning, etc. This warranty does not cover damage from lack of maintenance (lack of oil or water filter changes) freezing, and obstruction (due to scale, lime, dirt, chemicals, etc.)

Advanced Misting Systems is not responsible for the removal and shipping of the system to Advanced Misting Systems or a service provider, the reinstallation of the product upon its return to the customer, or any incidental or consequential damages resulting from the defect, removal, reinstallation, or shipment of the product.

Claims: All warranty claims must be submitted to Advanced Misting Systems prior to the expiration of the warranty period. Advanced Misting Systems will repair or replace any part of the fan product that is defective in material or workmanship. In order to initiate this warranty, the Product Registration Form must be completed and sent to Advanced Misting Systems, along with copy of original purchase invoice, within 30 days of purchase. Transportation charges on the product submitted for warranty must be borne by the purchaser. For warranty service, call Advanced Misting Systems for a Return Materials Authorization (RMA) number. Products shipped collect or without an RMA number will not be accepted.

If Advanced Misting Systems determines that the problem with the product is not due to defects in workmanship or materials, the customer will be responsible for the cost of any repairs and any freight expense to return the product to the customer. If the product is covered by this manufacturer's warranty, then Advanced Misting Systems will pay the freight to send the product back to the customer within the 48 continental United States ONLY.

No Other Warranties and Liability Limitation: This limited Warranty and Policy represents Advanced Misting Systems's sole and exclusive warranty obligation with respect to Advanced Misting Systems products. Advanced Misting Systems's liability to a customer or any other person shall not exceed the purchase price of the Advanced Misting Systems product. Advanced Misting Systems disclaims all other expressed and implied Warranties including the implied Warranties of fitness for a particular purpose and merchantability.

There is no other express warranty. Any and all implied warranties are excluded. Liability for incidental or consequential damages are excluded to the extent exclusion is permitted by law. This warranty gives you specific legal rights and you may also have other rights which vary from state to state and country to country.

Appendix

Parts Diagrams

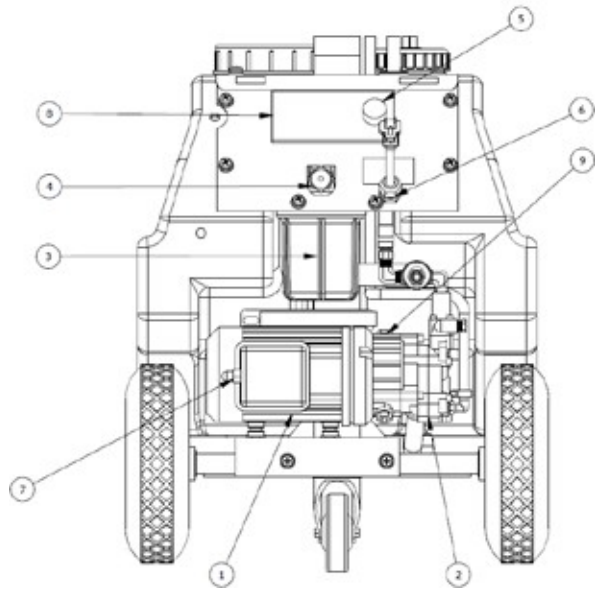

ITEM	DESCRIPTION
1	1/3 HP ELECTRIC MOTOR
2	WATER PUMP HEAD
3	WATER FILTER HOUSING
4	GARDEN HOSE INLET
5	FAN SPEED CONTROL KNOB
6	MAIN POWER CORD
7	MOTOR CIRCUIT BREAKER RESET SWITCH
8	PUMP CONTROL PANEL
9	OIL FILL PLUG LOCATION

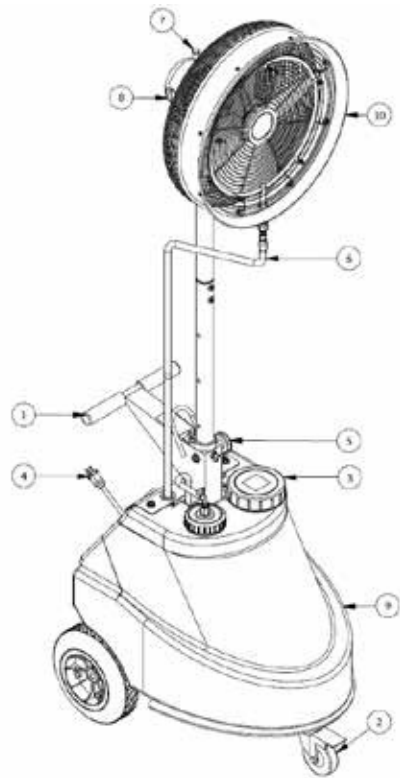

ITEM	DESCRIPTION
1	PUSH/PULL HANDLES AND MAIN FRAME
2	LOCKING FRONT CASTER WHEEL
3	AUXILLIARY FILL CAP
4	MAIN POWER PLUG
5	HEIGHT ADJUSTMENT SCREW
6	HIGH PRESSURE FAN SUPPLY HOSE
7	OSCILLATOR KNOB
8	FAN SPEED SELECTOR SWITCH
9	WATER TANK
10	FAN HEAD

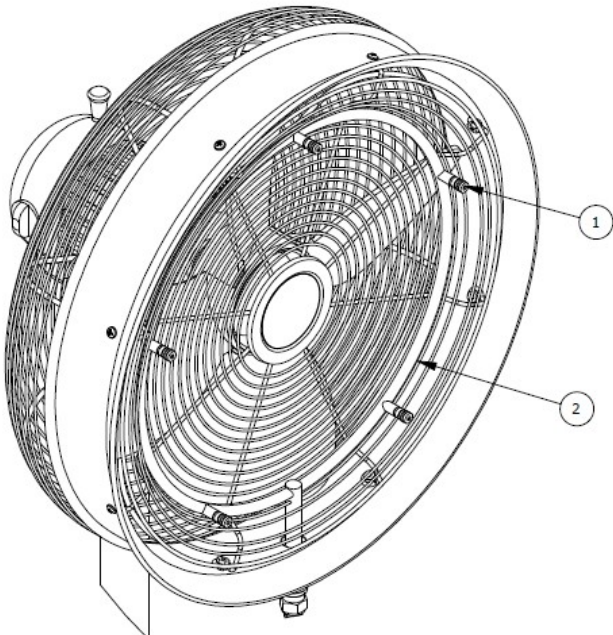

ITEM	DESCRIPTION
1	MISTING NOZZLE
2	MISTING RING

Control Panel

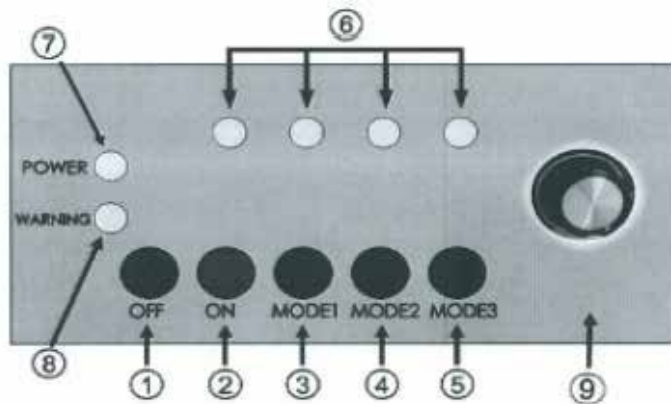

No.		Description
1	OFF	Power Off
2	ON	Continuous misting
3	MODE 1	Mist: 30 seconds / Stop: 30seconds
4	MODE 2	Mist: 40 seconds / Stop: 40 seconds
5	MODE 3	Mist: 50seconds / Stop: 50 seconds
6	INDICATOR LIGHT	Operating mode
7	POWER	Power On
8	WARNING	Indicator light: Lack of water supply
9	FAN SPEED	Adjust fan speed

Advanced Misting Systems
216 Avenida Fabricante Suite 207
San Clemente, CA 92672
www.advancedmistingsystems.com